



VYTAUTAS
MAGNUS
UNIVERSITY

Faculty of
Engineering

Bachelor Graduation Thesis

Methodological guidelines

AKADEMIJA, 2022

TABLE OF CONTENTS

INTRODUCTION	3
GENERAL REQUIREMENTS	4
1.1 Scientific adviser of the bachelor graduation thesis	4
1.2 General text requirements	4
1.3 General requirements for the graphic part	5
2. STRUCTURE OF THE BODY PART OF THE BACHELOR GRADUATION THESIS	6
2.1 Title page	6
2.2 Task and terms of reference of the bachelor graduation thesis	6
2.3 Summary	7
2.4 Table of contents	7
2.5 Explanatory vocabulary of abbreviations, symbols, units and terms	7
2.6 Introduction	7
2.7 Literature review	7
2.8 Project part	8
2.9 Conclusions	8
2.10 List of references	8
2.11 Annexes	9
3. FORMAL REQUIREMENTS FOR THE BACHELOR GRADUATION THESIS	10
3.1 Structural parts of the paper and writing of titles of chapters, subchapters, clauses and page numbering	10
3.2 Figures	10
3.3 Tables	11
3.4 Equations	11
3.5 Graphic part	12
4. DEFENCE PROCEDURE OF THE BACHELOR GRADUATION THESIS	13
5. GUIDELINES FOR PRESENTATION OF THE BACHELOR GRADUATION THESIS	14
5.1 Presentation plan	14
5.2 Computer software for presentation	14
LIST OF REFERENCES	15
ANNEXES	16

INTRODUCTION

These methodological guidelines apply to the bachelor graduation thesis in the Faculty of Engineering of Vytautas Magnus University Agriculture Academy, and provides the requirements for authors, scientific advisers and reviewers and are valid for faculty study programmes: Agricultural Mechanical Engineering, Smart Engineering, Hydraulic Engineering, Water and Land Engineering.

Bachelor graduation thesis is an individual work required for award of a qualification in a particular study field. Bachelor graduation thesis is the main document where a student applies his/her knowledge and demonstrates readiness for individual work. Quality of the work and the level of student's knowledge is evaluated by the Board of Graduation Thesis Evaluation.

These guidelines consist of five chapters and include the rights and duties of bachelor graduation thesis author and his scientific adviser, formal requirements and the structure of the bachelor graduation thesis, purpose and the requirements for various chapters, layout requirements and the description of the defence procedure in assessment board (public defence). Chapter six contains annexes (examples) for simplification of the preparation of the bachelor graduation thesis.

Student must demonstrate his/her knowledge acquired over the study period and should apply this knowledge according to the topic of the bachelor graduation thesis. A student (author of the work) is responsible for preparation of the bachelor graduation thesis, correctness of the results and technical solutions, quality of the text and drawings, conclusions and formatting of the work as well as guarantees that information in text was not plagiarized.

Authors are thankful for the reviewer assoc. prof. dr. Audrius Žunda for a valuable contribution and remarks.

GENERAL REQUIREMENTS

Bachelor graduation thesis can be defended if the student has passed all exams, prepared and submitted all term-papers, performed practices of the entire study programme.

At the end of a third study year, before engineering-project practice, student should select a scientific adviser according to the topics offered by any of the departments of the Faculty of Engineering. Topics of the bachelor graduation thesis must be specified until 15th of April of the current year.

Process of the preparation of the bachelor graduation thesis is supervised by the scientific adviser. Bachelor graduation thesis consists of text and graphic parts.

A student is responsible for the preparation of the bachelor graduation thesis and its quality, correctness of the results, conclusions and formatting of the work.

1.1 Scientific adviser of the bachelor graduation thesis

Scientific adviser of the bachelor graduation thesis:

- considers students' requests related to the desired subject, suggests the topic, prepares the terms of reference for the preparation of the bachelor graduation thesis;
- recommends main literature sources and other references;
- if the topic is related to experimental research, helps to make the experiment programme, methodology, select suitable equipment as well as advises by any questions related to data analysis and reliability;
- advises the student and recommends other potential consultants (if required);
- systemically supervises the schedule and the preparation status of the bachelor graduation thesis;
- reviews bachelor graduation thesis and assesses work in the grade scale of 10;
- advises student on any questions related with department submission and public defence;
- participates in the department defence of the bachelor graduation thesis.

1.2 General text requirements

Bachelor graduation thesis is written in English. Passive voice of verbs should be used (e.g., has been determined, analysed, suggested, etc.) instead of active voice (e.g. I have determined, I have found, etc.).

Recommended length of a work is from 35 to 45 pages prepared by the text editor including pictures, images or any other illustrations but excluding annexes. Text shall be typed on one side of A4 size (210x297 mm) portrait orientation paper sheet with the following margins: top and bottom 20 mm, left – 30 mm, right – 15 mm. First line of the paragraph should have the indent of 7 mm, text – justified, line spacing – 1,5 lines, font – Times New Roman 12 pt.

Text of the paper should include citations to references. Students might use any of two citation styles: in *angle brackets* when the references are identified by a number in ascending order from the beginning of the document (e.g. [7], [11, 17] etc.), or in *parenthesis* indicating author (-s) surname (-s) (or title of the document if the author is unknown or missing) and the publishing year, e.g. (Smith, 2014), (Smith *et al.*, 2015), (ISO 1234, 1997) etc. Only one of the above-mentioned citation styles should be used over the entire document.

Student must submit the printed version of the bachelor graduation thesis (signed by the student in the title page and below the conclusions) with drawings (one copy of each) and electronic version of all documents in a compact disc (CD).

Detailed layout and text requirements are provided in section 3.

1.3 General requirements for the graphic part

Graphic part of the bachelor graduation thesis should be presented in the drawings of the size A1–A4 and should include the schemes or drawings of any constructive, engineering-technical or technological solutions. Total number of drawings should be at least two A1 format pages (exact number is provided by a scientific adviser and stated in the terms of reference of the bachelor graduation thesis). It is obligatory to prepare at least one constructive or technological, assembly or part drawing (scheme) of A1 format**.

Notes:

- A1 format drawing or scheme can be replaced by the electronic version of the simulation of mechanism or technological process prepared by a computer software (simulation or video file should be included in the CD of the bachelor graduation thesis with the extension of *.avi or similar). Student must present the simulation on the projector's screen during presentation of the thesis;
- if the bachelor graduation thesis is scientific research, graphic part is not obligatory. Student should present the research results and discussion instead of the graphic part during presentation;
- graphic part of the bachelor graduation thesis for the study programme Transport Engineering must include schemes, drawings, diagrams etc. and should be present in text.

Each engineering solution must have the justification in the text of project part. Additional graphic part should be present in annexes.

** Does not apply to the study programme Transport Engineering.

2. STRUCTURE OF THE BODY PART OF THE BACHELOR GRADUATION THESIS

Body part of the bachelor graduation thesis consist of:

Title page.

Terms of reference of the bachelor graduation thesis.

Summary.

Table of contents.

Explanatory vocabulary of abbreviations, signs, dimensions, terminology (necessity is decided by a scientific adviser).

Introduction.

1. Literature review.

2. Project part.

Conclusions.

List of references.

Annexes (necessity is decided by a scientific adviser. Does not count into total pages).

2.1 Title page

Title page should include the identification of institution, author, title of the paper, study programme, scientific adviser, consultant (if applicable), reviewer, place and year of publish.

Template of the title page can be found in Annex A.

2.2 Task and terms of reference of the bachelor graduation thesis

Task and terms of reference of the bachelor graduation thesis is proposed by the scientific adviser after the discussion with student. Terms of reference should include the topic, detailed content of the work (table of contents), structure of the graphic part and timetable with deadlines for different chapters.

Task of the paper must be signed by a scientific adviser and student and approved by the head of the department. Additional space should be available below the task for the record of the department meeting which includes the grade of the department defence, date and the minutes' number of the meeting.

Template of the terms of reference can be found in Annex B.

2.3 Summary

Summary is a short outline of the content and main findings of the paper. Summary should include main statistical information of the paper (total number of pages, tables, figures, references as well as number and size of drawings). Text of the summary should present the novelty, essential results, generalized conclusions and keywords (up to 8 words) of the work.

Text of the summary should be of maximum 1 page.

Example of the summary can be found in Annex C.

2.4 Table of contents

Table of contents include the numbers of chapters and subchapter in which these chapters or subchapters begin.

Annex list and annexes should be presented in the end of the paper and are numbered independently (see subsection 2.11 for details).

2.5 Explanatory vocabulary of abbreviations, symbols, units and terms

Explanatory vocabulary must be present at the beginning of the work, in the following page after the table of contents. Vocabulary consists of symbols, abbreviations, symbols, terms and their definitions, measurement units and other information.

Necessity of the explanatory vocabulary is decided by a scientific adviser.

2.6 Introduction

Introduction should describe the relevance of the topic and develop a short discussion of the problem, should include aim and objectives of the work. Extent of the summary must be maximum 1 page.

2.7 Literature review

Chapter of the literature review must provide the analysis of scientific-technical, patent or any other information and should help to understand the advantages and disadvantages of various technologies, equipment or methods from various perspectives (economic, energetic, managerial, safety etc.).

Student must also prepare a short summary of the literature review at the end of the chapter (approx. 0,5 page) and introduce main tasks of the project part.

Chapter of the literature review can range from 12 to 18 pages.

Project part

Project part is the fundamental chapter of the work which includes the justification of the technical solution, its main constructive parameters and calculations of components, parts, drives, control schemes as well as other visual information which argues the expedience and validity of calculations. Project part can also discuss and improve the tasks related to safety, commerce, management, environmental safety, energetics, automatization etc. Students of the Transport Engineering study programme must use the computer-aided software for the design, modelling and simulation of the technical solution.

If the bachelor graduation thesis is of research type, experimental research programme, methodology and results should be presented in project part. Research question (area) should necessarily match the study field of the study programme.

Obligatory section of the project part is the assessment of the results which should include the assessment of the engineering solution from practical point of view as well as from various perspectives such as: economic, technical-technological, occupational health and safety, environmental protection, civil safety etc. Amount of this section should be 3-4 pages. Necessity of this section for the students of the study programme Transport Engineering is decided by a scientific adviser.

Total amount of project part should be from 15 to 22 pages.

2.8 Conclusions

Conclusions should answer to the tasks of the work formulated in the introduction. Conclusions should be clear, should match work title, aim and must be based on the main results. This section can also include recommendations and suggestions.

Conclusions must be numbered in Arabic numerals in ascending order.

2.9 List of references

References should be presented in original language in reference list. If the in-text citations are presented in angle brackets, they should be presented in the reference list the same order as were mentioned in text. If the in-text citations are presented in brackets and include author and year, reference list should be in alphabetical order: English first and any other characters (cyrilic etc.) after.

References should be presented according to the bibliographic requirements in the reference list (see examples in annex D).

2.10 Annexes

Annexes of the bachelor graduation thesis usually include tables, schemes or any other information that is not present in text. Each annex starts in a new page. Numbering of the annexes should start with the word “**Annex**” followed by capital Latin letters (A, B, C) which shows the annex identification. Title of the annexes should be written on the following line, regular font.

Annex number and title font size is 12 pt, written in top of the page, left aligned. One empty line should be left between the annex title and content information.

Annex’s table of contents should be inserted after the reference list before the annexes. This page must be included into total number of pages of the bachelor graduation thesis.

3. FORMAL REQUIREMENTS FOR THE BACHELOR GRADUATION THESIS

3.1 Structural parts of the paper and writing of titles of chapters, subchapters, clauses and page numbering

The body part of the bachelor graduation thesis is divided into chapters which have titles. Titles of the chapters (“**SUMMARY**”, “**TABLE OF CONTENTS**” etc.) must be written in a new page, centered, capital case, 14 pt, bold. Chapters “**1. LITERATURE REVIEW**”, “**2. PROJECT PART**” are numbered in Arabic numerals and can be divided into subchapters which can include clauses. Subchapters and clauses must be also numbered in Arabic numerals. Subchapter number consists of the number of the subchapter in chapter, while the clause number includes the number of chapter, subchapter and clause number in subchapter. Text of subchapters and clauses should be written in sentence case, centered, 12 pt bold. Numbers of chapters, subchapters and clauses are separated by commas, but commas should not be written in the end of the chapter title. For example, chapter “**1. LITERATURE REVIEW**”, subchapter “**1.1. Harvester grain separation equipment**”, clause “**1.1.1. Sieves**”. Text must be separated from titles of chapters, subchapters and clauses by one empty line, while by two lines before the titles of chapters.

Pages must be numbered in Arabic numerals (12 pt) starting from the title page, but the page numbering should start from the chapter “**1. LITERATURE REVIEW**”, in the footer of the page, right aligned (header from bottom – 12,5 mm). Title page, task of the paper, summary, table of contents and the explanatory vocabulary shouldn't be numbered but are included into total number of pages.

3.2 Figures

Figures (charts, diagrams, schemes, photos) are presented in text after they have been first time mentioned. Good practice is not to use the drawings of large dimension as well as uninformative figures. Figure numbering in Arabic numerals is based on individual chapters (first number is the number of the respective chapter that the figure is presented in, while the last number is the number of the figure in the chapter). Number of a figure is written below the figure in **bold**, followed by the title of the figure (e.g. “**Fig. 1.1.** Title of the figure”). Title of the figure might be followed by the explanations of the parts (if present). Figure title is then separated from explanations by a colon, while the explanations one from another by semicolons. If the figure has been taken from any source, reference should be presented after the title of the figure but before explanations. No comma should be written at the end of the figure title.

Figure number, title and explanations are written in 11 pt, no first line spacing, justified.

Figure should be separated from body text by the 12 pt empty lines before the figure and after the title. Text size in figure (if present) should be written in 11 pt font.

Example of figure formatting is provided in Annex E

3.3 Tables

Tables, as well as figures are presented in text after they have been first time mentioned. Table numbering in Arabic numerals is same as for figures. Example, “**Table 1.3.** Technical parameters of the harvester separation system“. If the information in the table or the entire table is of another author (-s), reference must be indicated after the title of a table.

Number of the table is presented above the table (11 pt) with no first line spacing, centered. Single empty lines of 12 pt must be present before the title of table and after the table. If the table does not fit into one page it can be extended in the following page. Notation “**Continuation of Table 1.3**” (in bold) must be present on the right side of the second page above the table. Table text should be written in 11 pt.

Example of table formatting is provided in Annex E.

3.4 Equations

Equations are written using “*Microsoft Equation*” or similar equation tools according to the recommendation of symbols’ writing: all Latin letters and lowercase Greek symbols (A , a , α , β etc.), except mathematical functions (sin, tg, max, lim etc.) must be written *italic* in equations and text while the numbers (1, 4, a_1 , β_2 etc.), Greek capital letters (Δ , Σ , Ω ir kt.) and measurement dimensions (e.g., $\text{m}\cdot\text{s}^{-1}$, $\text{m}^3\cdot\text{s}^{-1}$) – using the regular font. Equation indent from left is 15 mm, justified and 1,5-line spacing interval.

Symbols, coefficients and their values are explained in the following line below the equation. Explanation begins with the word “where” followed by the symbol and its explanation in order of occurrence in the respective equation. If the equation contains two or more symbols, word “where” should be followed by the colon. Each new symbol is explained in a new line. Text lines with symbols’ explanations should be justified, 1,5-line spacing, text size – 12 pt, first line indentation – 0,7 cm (except the first symbol which is in the same line as the word “where” and starts at the 0 cm indent from left).

Dimension units of the symbols should be indicated after the explanations of a symbols, except these cases, when the symbol is non-dimensional. Measurement units in text, charts and equations should be written in regular font. Units should be used by using the sign of multiplication (\cdot), while for division – denominator is exponented by a degree of -1 and moved to

numerator. For example, speed should be indicated „m·s⁻¹“ instead of „m/s“, flow debit – „m³·s⁻¹“, instead of „m³/s“, angular acceleration – „s⁻²“, instead of „rad/s²“ et cetera. Percentage expressions should be indicated by using the percent sign (%) after the numeric value followed by space (e.g. 45 %). For the indication of angle, no space between number and angle sign is required (e.g. 45°) but vice versa for indication of temperature – space is required (45 °C instead of 45°C).

Dashes should be written according to the requirements as follows:

- Long dash with no spaces („–“): 16:30–17:00, 3–4, 1999–2000 m., Vilnius–Kaunas;
- Long dash with spaces („ – “): May 18 – June 1, ages X – XI;
- Short dash without spaces („-“): customer-supporter, physical-mechanical properties, Adams-Smith etc.

Equations should have identification. Numbers of the equations should be in parenthesis, aligned to the right of the page. Equation number consists of the number of the respective chapter that the equation is presented in, while the last number is the number of the equation in the chapter. Equations can be also numbered in sequence throughout the paper. One empty line should be present before the equation and after the explanation of symbols. Reference should be indicated before the equation has been used.

Example of equation formatting and character description is provided in Annex E.

3.5 Graphic part

Drawings of the graphic part should be prepared using the specialized computer software. Drawings should fulfil the standard requirements and have the required additional information: technical characteristics, specifications of mechanisms, components, sketches or parts, explications or any other denotations. Drawings should be prepared following the requirements for engineering drawings such as proper orthogonal views, cutaways, breaking lines, dimension styles, detail and their element marking, line weight and similar requirements. Drawings must be informative and appropriately present the object, technological process or scheme.

Identification data of the drawing are presented in the drawing's title block which is included to every single page and must be signed by the author, scientific adviser and reviewer.

4. DEFENCE PROCEDURE OF THE BACHELOR GRADUATION THESIS

Bachelor graduation thesis of the bachelor's studies are first defended at the department by an attestation commission approved by the dean of the faculty according to the schedule approved by the head of the department. No later than 3 days before the defense at the department, the student sends the explanatory note and drawings of the bachelor graduation thesis (in pdf format) by e-mail specified by the head of the department. During the defense, the student presents the work and answers questions. The members of the attestation commission assess the compliance of the paper with the mandatory requirements, taking into account the quality of the work and drawings, formalization and presentation, the compliance with the formal requirements and the answers to the questions: If the recommendation of the attestation commission of the department is not to submit the thesis for public defense as unsatisfactory, the bachelor graduation thesis shall not be submitted for public defense. The theses defended at the department are submitted for public defense in accordance with the approved procedure for submitting the bachelor graduation thesis of the FACULTY OF ENGINEERING STUDENTS TO THE PUBLIC DEFENSE. The public defense of the bachelor graduation thesis takes place at a public meeting of the the Board of Graduation Thesis Evaluation. The Board of Graduation Thesis Evaluation may work if more than half of its members are present at the meeting. The Dean's Office provides each member of the Board with information on the student's study results. Procedure for submission of bachelor graduation thesis to the Board of Graduation Thesis Evaluation:

- ♣ The chairman of the Board of Graduation Thesis Evaluation introduces the author of the thesis and gives him the floor for the report;
- ♣ the author presents his work, the duration of the report is 7 ... 10 minutes;
- ♣ Questions to the rapporteur. The questions are submitted by the Board of Graduation Thesis Evaluation, as well as other participants of the meeting. The rapporteur answered questions;
- ♣ The reviewer reads the review. If he is absent for objective reasons, the review shall be read by a representative of the department from which the reviewer was appointed;
- ♣ The rapporteur answers the reviewer's comments or questions (if any);
- ♣ At the discretion of the chairman of the board, the head and other participants of the meeting may be given the right to speak;
- ♣ At the end of the meeting, the Board of Graduation Thesis Evaluation discusses and evaluates the defended theses in a closed meeting;
- ♣ The chairman of the board publicly reviews the results of the thesis evaluation in the presence of the members of the board and other participants of the meeting. Each student is informed personally about the final evaluation of the individual thesis. Negative theses may be re-defended after one year.

5. GUIDELINES FOR PRESENTATION OF THE BACHELOR GRADUATION THESIS

5.1 Presentation plan

Presentation should include the following:

- 1) title slide and introduction (faculty, study programme, department, topic, student, scientific adviser);
- 2) novelty of the topic, aim and the tasks of the work;
- 3) main findings of the literature review and the project part;
- 4) conclusions.

Starting the presentation student should appeal to commission, for instance “Dear commission members, I’ll present my bachelor graduation thesis of the bachelor’s studies topic of which is “.....”. Good practice is to mention the scientific adviser and reviewer as well as the department where the paper has been prepared. One of the main parts of the presentation is the emphasis of the topic relevancy i.e. what problems are still unsolved and what is the aim of the work. Student should also formulate tasks of the work which should help to achieve the main aim.

During the presentation, presenter must shortly describe which aspects were analysed in the chapter of literature review, what was the programme of the project part and what are the main findings and the conclusions of the work. Following slides and the oral presentation should introduce main calculation results of the project part as well as evaluation of the results.

Presentation must be finished with conclusions and their generalization.

Total duration of the presentation should be maximum 10 minutes.

5.2 Computer software for presentation

Presentation should be prepared using the computer software such as „Power Point“, “Media Player“ or others and presented on the projector screen during defence. Title slide should have the presentation information, second should include the novelty and aim of the work while the following slides should present basic ideas of the work and conclusions.

For the presentation of the results of the project part it is recommended to use printed drawings and additionally show them in the slides (for the emphasis or magnification of essential views and ideas).

LIST OF REFERENCES

1. ŠARLAUSKIENĖ, L. 2014. *Studijų rašto darbų įforminimo bendrieji metodiniai patarimai ASU studentams* [interactive]. Akademija [viewed 2015-02-07]. Online access: <http://dspace.lzuu.lt/handle/1/3061>
2. ŠARLAUSKIENĖ, L. 2014. *Bibliografinių nuorodų ir literatūros sąrašų sudarymas: metodiniai patarimai*. Akademija, Kauno r.: Aleksandro Stulginskio universiteto Leidybos centras.
3. LST ISO 690:2002. *Dokumentai. Bibliografinės nuorodos. Turinys, forma ir sandara* (tapatus ISO 690:1987). Vilnius: Lietuvos standartizacijos departamentas.
4. LST ISO 690:1999. *Informacija ir dokumentai. Bibliografinės nuorodos. 2-oji dalis. Elektroniniai dokumentai ir jų dalys*. Vilnius: Lietuvos standartizacijos departamentas.
5. LST ISO 10209-1:2005. *Techniniai gaminių dokumentai. Terminai ir apibrėžtys. 1 dalis. Bendrieji techninių brėžinių ir jų tipų terminai*. Vilnius: Lietuvos standartizacijos departamentas.
6. LST EN ISO 7200:2005. *Techniniai gaminių dokumentai. Duomenų laukai pagrindinėse įrašų lentelėse ir dokumentų antraštėse*. Vilnius: Lietuvos standartizacijos departamentas.

ANNEXES

Annex A. Template of the title page

Annex B. Terms of reference of the bachelor graduation thesis

Annex C. Example of the summary of the bachelor graduation thesis

Annex D. Bibliography requirements and examples

Annex E. Formatting examples of the body text elements

Annex F. Requirements for the drawings of graphic part

VYTAUTAS MAGNUS UNIVERSITY

(Times New Roman, 12 pt, Bold)

FACULTY OF ENGINEERING

(Times New Roman, 12 pt)

Department of Agricultural Engineering and Safety

(Times New Roman, 12 pt)

> 6 pt

> 6 pt

TITLE OF THE BACHELOR GRADUATION THESIS

(Times New Roman, 18 pt, Bold)

Bachelor graduation thesis of the Bachelor's studies

(Times New Roman, 14 pt)

Study programme: Agricultural Mechanical Engineering

(Times New Roman, 14 pt)

> 12 pt

> 6 pt

Author: Name, Surname /signature/

(Times New Roman, 12 pt)

Scientific adviser:

prof. Name, surname /signature/

(Times New Roman, 12 pt)

Reviewer: lect. Name, surname /signature/

(Times New Roman, 12 pt)

> 12 pt

> 12 pt

Akademija, 2022

(Times New Roman, 12 pt)

VYTAUTAS MAGNUS UNIVERSITY

Faculty of Engineering
Department of Agricultural
Engineering and Safety

Study programme of Agricultural
Mechanical Engineering

APPROVED:

(head of the department)

..... (day) of (month), 2022

**BACHELOR GRADUATION THESIS OF BACHELOR’S STUDIES
TERMS OF REFERENCE**

Student **NAME SURNAME**

Topic Galega orientalis Lam seed harvest technology

Content of the paper: SUMMARY. TABLE OF CONTENTS. INTRODUCTION 1. 1. LITERATURE REVIEW 1.1. Galega orientalis Lam. 1.2. Seed production of the Galega orientalis Lam 1.3. Technology of the seed harvest technology 1.4. Review of the combine harvester separators 1.5. Analysis of the patent information 1.6. Summary of the literature review 2. PROJECT PART. 2.1. Justification of the separation device 2.2. Calculations of the separation device. 2.3. Exploitation of the separation device 2.3. Economic evaluation of the solution. CONCLUSIONS. LIST OF REFERENCES.

Graphic part: two A1 format drawings, with the general view of separator and part’s drawings of the parts.

Deadlines:

Stages	Deadlines
Literature review	2022
Project part	2022
Result evaluation	2022
Graphical part	2022

Deadline for the submission of the bachelor graduation thesis (day) of (month), 2022.

Students’ signature	Signature of scientific adviser	assoc. prof. P. Petraitis
_____	_____	_____

Department decision: _____

Minute’s No. _____ Date (day) of (month), 2022

(signature of the head of the department)

Example of the summary of the bachelor graduation thesis

Juozaitis J. Oilseed Rape Harvesting Technology: Bachelor graduation thesis in study programme Agricultural Mechanical Engineering / scientific adviser: assoc. prof. dr. P. Petraitis; Department of Agricultural Engineering and Safety, Faculty of Engineering, Vytautas Magnus University. – Akademija, 2022. – 39 p.

SUMMARY

Summary should begin with main information of the paper such as total number of pages, tables, figures, references as well as number and size of drawings. Summary should present the novelty, essential results (in two or three sentences) and shortly describe the ideas of engineering solution. Summary should also include generalized conclusions and keywords (up to 8 words) of the work. Summary must be of 150 words at least, but should not exceed one page.

Books ①

1. KIRKA, A. 2009. *Hidrostatinių pavary parametrų skaičiavimas*: mokomoji knyga. Akademija, Kauno r.: Lietuvos žemės ūkio universiteto Leidybos centras.
2. BRAŽIŪNAS, A. J. 2009 *Mašinų gamybos technologijos pagrindai: vadovėlis aukštųjų mokyklų studentams*. Kaunas: Kauno technologijos universitetas.
3. TICKOO, S. 2010. *Solid Edge ST2 for Designers. CAD/CIM Technologies*.
4. JANULEVIČIUS, A.; PUPINIS, G. 2012. *Ratinių mašinų teorijos pagrindai: mokomoji knyga*. Akademija, Kauno r.: Aleksandro Stulginskio universitetas.
5. DOROŠEVAS, V. VYŠNIAUSKIENĖ, Ž. 2007. *Trumpas teorinės mechanikos kursas: vadovėlis*. Kaunas: Kauno technologijos universitetas.
6. *Lietuvos kaimo ateitis. Žalioji knyga*. 2010. Vilnius: Lietuvos agrarinės ekonomikos institutas.

Scientific papers, dissertations ①

7. LABECKAS, G.; SLAVINSKAS, S.; VILUTIENĖ, V.; KANAPKIENĖ, I. 2014. Dependency of the Autoignition Delay, Combustion and Exhaust Emissions of a Diesel Engine on the Cetane Number of Aviation-Turbine Jp-8 Fuel. *Agricultural engineering = Žemės ūkio inžinerija*, no. 46(1), p. 23–39.
8. ZASČIURINSKAITĖ, E.; VOLKAVIČIŪTĖ, Ž.; ZVICEVIČIUS, E. 2014. Šviežių topinambų gumbų laikymo technologijų palyginimas. *Agroinžinerija ir energetika: ASU Žemės ūkio inžinerijos fakulteto mokslo populiarinimo ir gamybos žurnalas*, no. 19, p. 3–7.
9. KAVOLYNAS, A.; NAVICKAS, K.; VAICKELIONIS, E. 2012. Saulės energijos naudojimo galimybės automatinės telekomunikacijų stoties mikroklimato sistemoje. *Šilumos energetika ir technologijos - 2012: conference proceedings*, 2, 3 of February, 2012 / Kaunas University of Technology, Lithuanian Energy Institute p. 31-34.
10. BAGDONIENĖ, I. *Amoniako emisija iš galvijų mėšlo kintančių mikroklimato veiksmių aplinkoje*: daktaro disertacija: technologijos mokslai, aplinkos inžinerija (04T) Akademija, [Kauno r.].

Magazines and newspapers ①

11. ŠPOKAS, L. 2014. Javų kombainų konstrukcijos naujovės. *Mano ūkis*, No. 8, p. 65–70.
12. FEIZIENĖ, D.; FEIZA, D. 2010. Žemės dirbimo įtaka dirvožemio tausojimui. *Mano ūkis*, nr. 3, p. 7–9.
13. Nacionalinė atsinaujinančių energijos išteklių plėtros strategija. 2010. *Valstybės žinios*, nr. 73-3725.
14. JANUŠAUSKAS, R. 1998. Geresnės nuomonės apie kaimynus ne tik Briuselis. *Verslo žinios*, birželio 24, p. 7.

Standards ①

15. ISO 690: 2010. *Documentation -- Bibliographic references -- Content, form and structure*
16. *Dokumentai. Bibliografinės nuorodos. Turinys, forma ir sandara* (tapatus ISO 690:1987). Vilnius: Lietuvos standartizacijos departamentas.
17. *LST EN ISO 9000:2007. Kokybės vadybos sistemos. Pagrindai ir aiškinamasis žodynas (ISO 9000:2005) = Quality management systems. Fundamentals and vocabulary (ISO 9000:2005)*. Vilnius: Lietuvos standartizacijos departamentas.
18. *LST EN 14214:2008+A1:2010. Automobiliniai degalai. Riebalų rūgščių metilesteriai (RRME), skirti dyzeliniams varikliams. Reikalavimai ir tyrimo metodai* (tapatus EN 14214:2008+A1:2009). Vilnius: Lietuvos standartizacijos departamentas.

Sources of statistical data

19. Pagrindiniai žemės ūkio produkcijos gamybos rodikliai. 2014. Iš *Lietuvos statistikos metraštis*. Vilnius: Lietuvos statistikos departamentas, p. 606–621.
20. Output of the agricultural industry – basic and producer prices. 2014. *EUROSTAT* [interactive], [viewed 2014-11-20]. Online access: <<http://epp.eurostat.ec.europa.eu/tgm/table.do?tab=table&init=1&language=en&pcode=tag00102&plugin=1>>.

Electronic references are presented following the same requirements as for printed documents, additionally indicating the type of the source, viewing date and website address as follows:

E-book

20. BLEIZGYS, R.; ČESNA, J. 2012. *Gyvininkystės technologijų inžinerija: mokomoji knyga* [interactive]. Akademija (Kauno r.): Aleksandro Stulginskio universiteto Leidybos centras, [viewed 2014-02-10]. Online access: <<http://dspace.lzuu.lt/handle/1/2028>>.

Article from e-magazine

21. ABALIKŠTIENĖ, E.; ALEKNAVIČIUS, P. 2013. Žemės ūkio paskirties žemės naudojimo tendencijos nenašių žemių savivaldybėse. *Žemės ūkio mokslai* [interactive], No. 20, iss. 3, p. 159–169 [viewed 2014-02-10]. Online access: <<http://dx.doi.org/10.6001/zemesukiomokslai.v20i3.2739>>.

Article from e-book

22. MULDER, C.; et al. 2013. Chapter Two - Connecting the Green and Brown Worlds: Allometric and Stoichiometric Predictability of Above- and Below-Ground Networks. In *Advances in Ecological Research* [interactive] Academic Press, vol. 49, p. 69–175 [viewed 2014-02-10]. Online access: <<http://dx.doi.org/10.1016/B978-0-12-420002-9.00002-0>>

- ① **Important notice:** list of references should not contain separate sections such as “Books”, “Scientific articles, dissertations”, “Journals and newspapers” etc.

*Example of table layout***Table 2.1.** Influence of the impact duration of abrasive material on micro-hardness of the steel 65G

Indenter load Q , N	Duration of the abrasive influence τ , h			Average micro-hardness HV , MPa
	0	20	120	
0,2	4580	4150	6950	5230
0,5	5320	8400	7700	7140

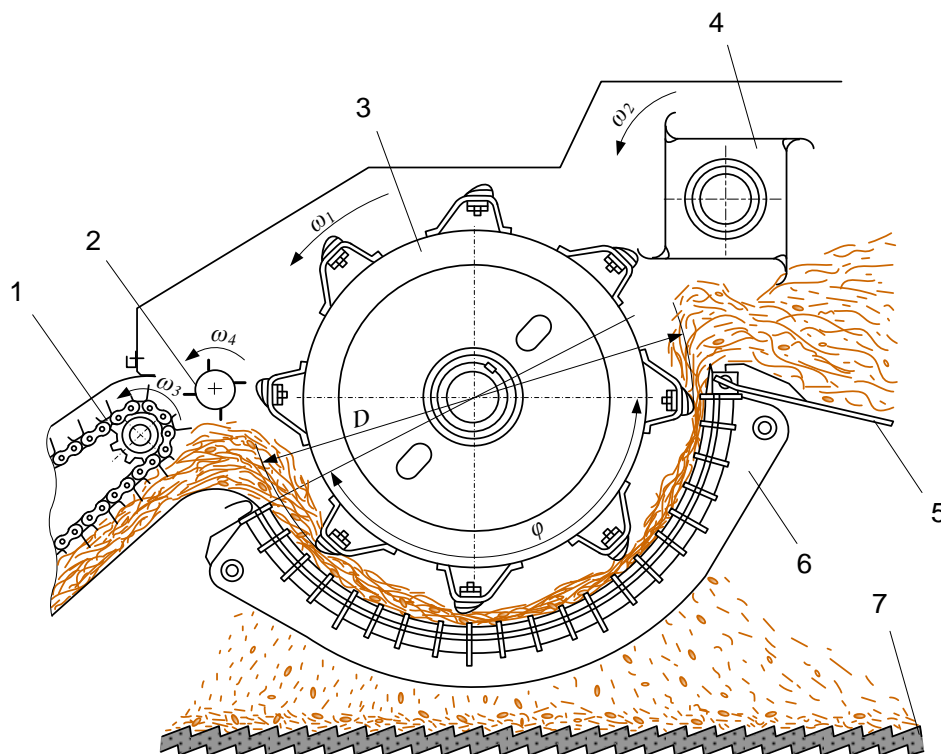
Example of figure layout

Fig 1.1. Scheme of the threshing-separation device of grain: 1 – grain conveyor; 2 – pre-threshing drum; 3 – threshing drum; 4 – rear beater; 5 – grate-bar sieves; 6 – concave; 7 – grain pan; D – diameter of the threshing drum; ω_1 – angular speed of threshing drum; ω_2 – angular speed of rear beater; ω_3 – angular speed of grain conveyor shaft; ω_4 – angular speed of pre-threshing drum; φ – convexity angle of the concave

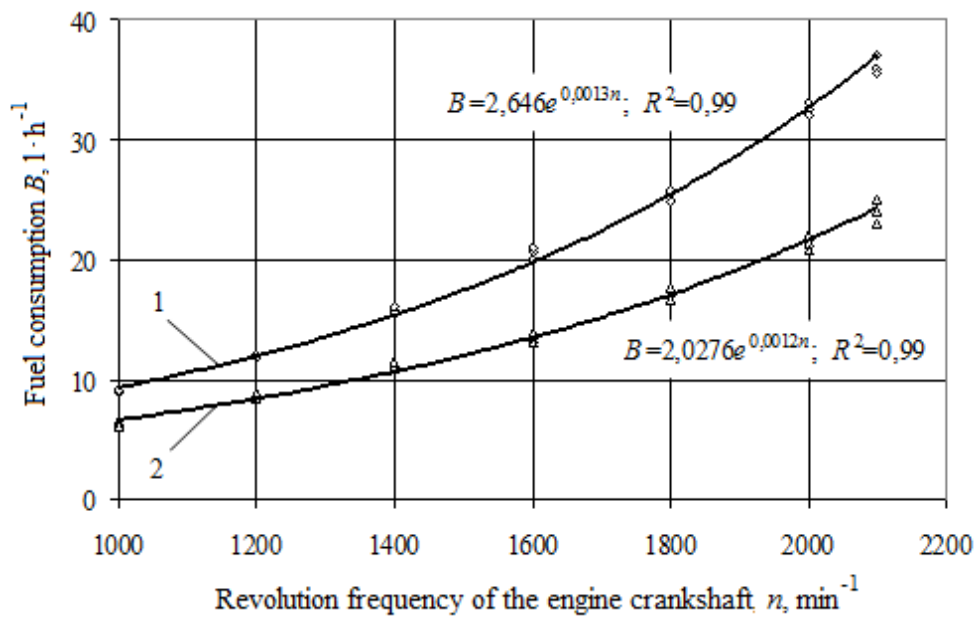


Fig. 1.2. Dependence of the hourly fuel consumption B as a function of revolution frequency of the engine crankshaft n : 1 – when the drives of cutter bar, threshing and straw chopper are on; 2 – when all drives are off.

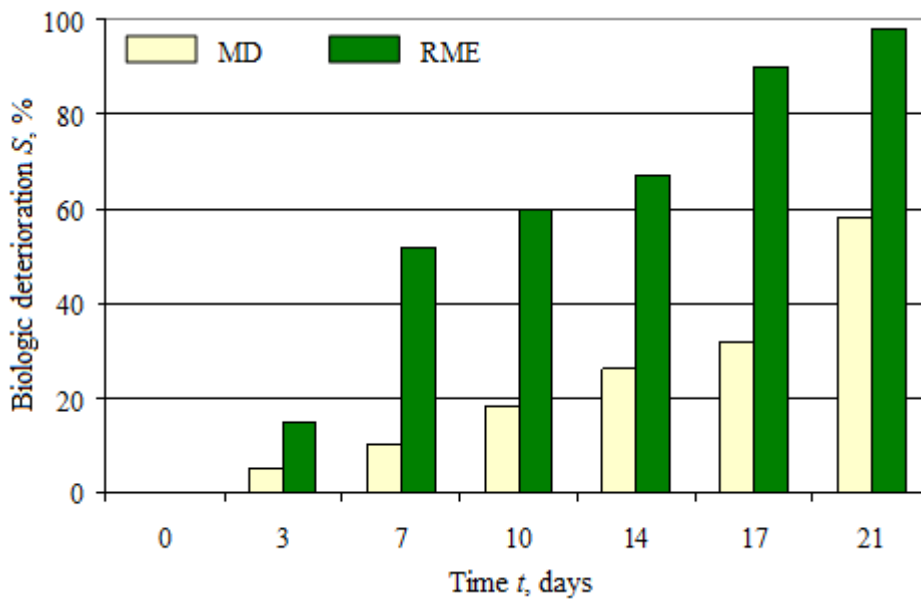


Fig. 1.3. Dynamics of biologic deterioration of rape oil methyl ester RME and mineral diesel MD

Example of equation writing and numbering

Coefficient of the dynamic friction f_d between the material and the sustaining plane is calculated as follows (Reference, 2000):

$$f_d = \text{tg}\beta - \frac{2S}{gt^2 \cos \beta}, \tag{1.1}$$

where: β – angle with the horizontal plane, $^{\circ}$;

S – movement distance of the material, m;

g – acceleration of gravity, $\text{m}\cdot\text{s}^{-2}$;

t – duration of the material movement, s.

Types of the documents in graphic part

Graphic part of the bachelor graduation thesis consists of *graphic* (drawings, schemes) and *written* (specification) documents. These documents separately or jointly give the information of technological process, control scheme or object, its construction, data of manufacturing, control, rules of usage or amendment.

All *graphic documents* (except drawings and schemes) have their identification codes provided in table 1.

Table 1. Types and codes of documents in the graphic part

Type of the engineering drawing	Code
Sketch drawing	EB
Primary drawing	PB
Theoretical drawing	TB
Outline drawing	GB
Installation drawing	MB
Installation drawing of electric equipment	ME
Detailed drawing	DB
Unit assembly drawing	SB
Assembly drawing	BS
Part drawing	
Scheme	
Specification	

Sketch drawing – document, holding the data of construction principles and which provides the information about the structure, principle and main parameters of the object. Sketch is usually a scale free hand-drawn picture.

Primary drawing – drawing which acts as a base for final decision of interested parties. When developing a complex product, engineering process might include professionals of various fields, such as specialists of ergonomics, industrial design etc. Following the primary task, designer prepares the *primary* drawing which is the base for detailed projects of construction, design or ergonomics.

Theoretical drawing – shows the shape (contours) of the object and coordinates of the various parts.

Outline drawing – presents simplified contour view of the unit, contour dimensions and mass. These drawings are used for the purposes of packaging, transportation, positioning or connection of various objects.

Installation drawing – shows the view of elements' contours (usually simplified) and information needed for the mounting of the unit. Installation drawings are, for instance, building base drawings with information about the location of various elements.

Installation drawing of electric equipment – includes the data needed for the installation of electric devices.

Detailed drawing – document which usually present the *magnified* part and additional information about their shape, construction, assembly and tolerances. Detailed drawing is the base for design and helps to prepare assembly or working drawings. These drawings include outlines and inter-connection dimensions of various parts as well as titles and number of composing parts, technical requirements and simplified views of the parts.

Unit assembly drawing – reference document required for the assembly of the unit. Unit assembly drawing depicts the information of a *large group* of parts, their inter-relations or other data, needed for the assembly of the unit.

Assembly drawing – includes *all* elements, parts and relations between these parts and presents the principle of operation of the final object. Assembly drawing is created from several units' assembly drawings.

Part drawing – is the view of single part (which cannot be disassembled) and all required information for a production of that part.

Scheme – graphic document with arbitrary signs and symbols which presents the logical links between different components of the system but does not include kinematic, hydraulic, pneumatic or electric scheme.

Specification – list of the elements of the unit or identification of consisting parts in assembly drawing.

Title block of the graphic part documents

Any document of the graphic part must have the title block (stamp). Table of the title block is the main attribute of the drawing and is drawn on the bottom right corner in every single page.

Width of the title block is 180 mm for A4 page format with the left margin of 20 mm and right margin of 10 mm. Title block of the above-mentioned dimensions is also used in other page formats. Requirement for title blocks are available in the international standard ISO 7200:2005. Recommended dimensions and shapes of the title blocks are given in figures 1 and 2.

Dimensions of the title block and its content for the drawings of *scheme type* is presented in figure 1.

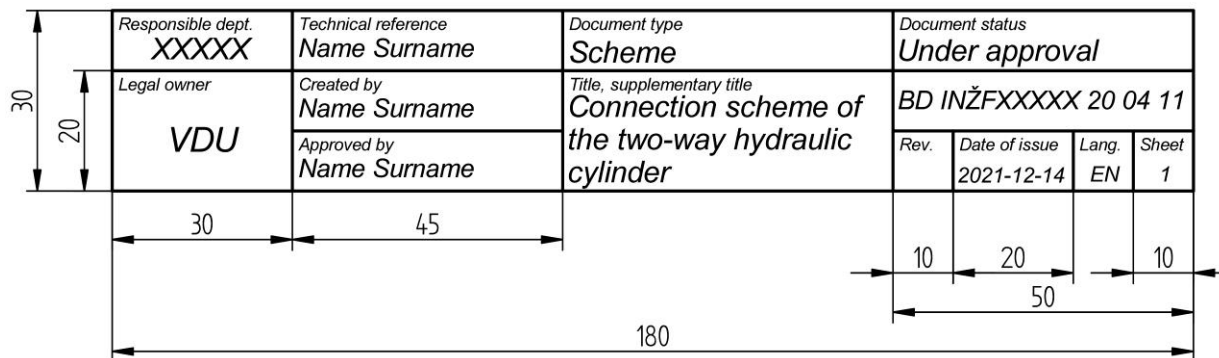


Fig. 1. Title block for the schemes

Template and data field dimensions and example for any other drawings (except specification) is given in figure 2. This title block must have the extra line for additional information (symbol of projection method, material and scale).

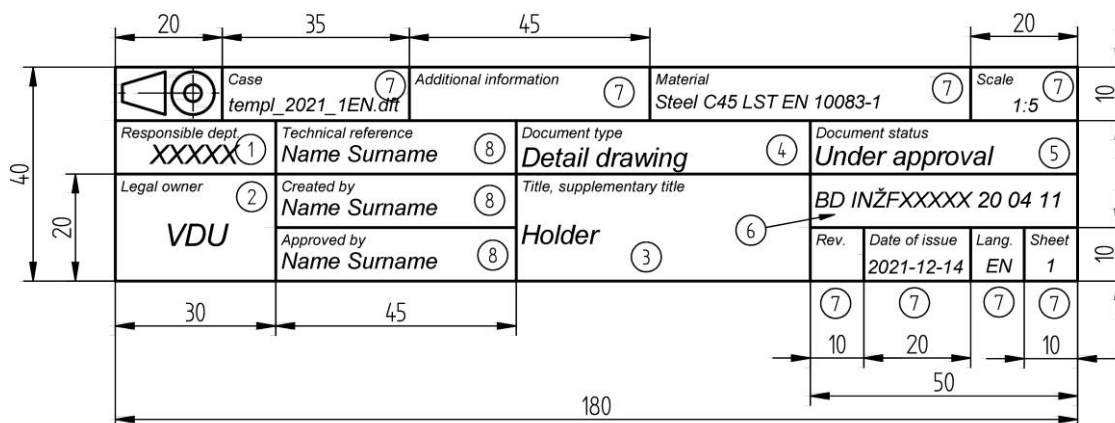


Fig. 2. Title block for the technical drawings

Data fields in title blocks should meet the requirements of the standards ISO 3098-1:1996, ISO 3098-5:2000. Font for table's elements – Arial italic. Text size for the titles of the fields (for example “Responsible department”, “Technical reference”) is 2 mm; for content of fields ①, ③, ④ and ⑤ – 3,5 mm; for identification ⑥ – 3,5 mm; for content of fields ⑦ - 2,5 mm, for

content of fields ⑧ - 3 mm; owner ② *VDU* font size – 4 mm. The font size of the fields may be reduced if the width of the field is insufficient to place the required content.

Information, provided in the fields of title block:

- **Responsible department** ① – abbreviation of the department where the final work was prepared, e.g.: “Department of Agricultural Engineering and Safety” – *ŽŪISK*; “Department of Mechanical, Energy and Biotechnology Engineering” – *MEBIK*, “Department of Water Engineering” - *VIK*.
- **Legal owner** ② – abbreviation of the name of the document owner i.e. „Vytautas Magnus university” – *VDU*.
- **Title** ③ – the title refers to the content of the document e.g. *Equipment arrangement scheme*; „*Pipe clamp*“; „*Clutch*“ etc. Title may also have supplementary title, e.g. “*Pipe clamp with support*”. Important: abbreviations should be avoided in titles.
- **Document type** ④ – indicates the role of the document with respect to its content of information and representation format e.g. „*Assembly drawing*“, „*Part drawing*“ etc.
- **The document status** ⑤ shows where the document is in its life cycle. The status is indicated by means of terms such as “*In preparation*”, “*Under approval*”, “*Released*” and “*Withdrawn*”. For the bachelor graduation thesis, it is recommended to use the status “*Released*” while for project or any other works – “*Withdrawn*”.
- Field number ⑥ is for **identification number** (see Fig. 3):
 - a) first two letters *DP* – diploma project; *BD* – bachelor graduation thesis of the bachelor’s studies; *KP* – term paper; *ND* – individual homework;
 - b) abbreviation of the department: *ŽŪISK*, *MEBIK*, *VIK*;
 - c) no. of study subject (2 or 3 symbols) in the code of the study subject. This field should be empty for bachelor graduation thesis;
 - d) last two numbers of the current year;
 - e) two zeros (are indicated *only* in assembly and detailed drawings);
 - f) code of document type (if present) (see table 1).

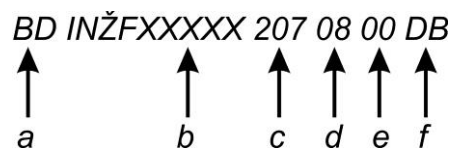


Fig. 3. Structure of the identification number of drawings

Additional comments:

- identification of the *assembly* (sub-assembly) *drawing* shall be presented by the two numbers assigned to the group of parts (assembly unit) in the detailed or assembly drawing before the document type code, e.g. *BD INŽFXXXXX 08 03 SB*;
- in the *part drawing* 2-digit part number (which identifies the part in assembly drawing) must be presented instead of document type code e.g.: *BD INŽFXXXXX 08 03 11*;
- if both *DB* and *BS* drawings types were used in the work, after the part number, type of the drawing must be identified (in brackets), to which that part drawing is attributed, e.g.: *BD INŽFXXXXX 08 03 11 (BS)*.

Graphic symbol of the projection method should be showed in the top line of the title block of the part (fig. 2) which means that the part is presented using the *first angle project method*. This means that the object is conceptually located in quadrant, i.e. it floats above and before the viewing planes, the planes are opaque, and each view is pushed through the object onto the plane furthest from it (so called *European method*).

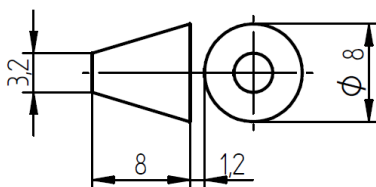


Fig. 4. Graphical symbol of the project method according to the European method

Specification table should include the following information (Figs. 5, 6 and 7):

- The **“Revision index”** identifies the revision status of the document. Different versions are numbered in consecutive order by means of, e.g. a letter combination A to Z. For example: A – primary version; B – edited (secondary) version; C – supplemented version etc.
- **„Sheet”** – first number shows the page number while the second – total number of pages.
- **Specification table** – list of the consisting parts (Figs. 4, 5 and 6) should be prepared for each unit that is presented in assembly drawing (can include documentation, units, parts, standard parts, materials etc.). Numbers of the parts in specification must be the same as marking of the part in assembly drawing.
- Specification section **„Documents”** (Fig. 5) defines the ID of assembly drawing, to which specification is attributed.

- Specification section „**Conjuncts**“ (not given in specification in Fig. 5) defines the parts of the unit assembled according to different assembly drawings. This section usually present al-in-one (welded, brazed) parts or various parts of technically complex machines (agricultural machinery, machine tools etc.) which are assembled according to various drawings.
- Section „**Components**“ (Fig. 5) must include every consisting component of the unit. If a component has no working drawing, additional information such as material, dimensions etc. must be present in specification table.
- „**Standard components**“ (Fig. 5) include each standard part and other belongings and their standards.

Specification can be provided in A4 pages (Figs. 5, 6) or in assembly drawing (Fig. 6). If the specification is in different page, it must be identified by the same number as the assembly drawing. Any specification records are done in the direction from top to bottom, header row – in the top (Figs. 5 and 6). Contours of the specification table are drawn with the thick black line of 0,5 mm (the same with as for main line for drawings), rows are separated by a thin line of 0,25 mm. It is recommended to make records in capital letters. When the list of the components of the assembly drawing is in multiple pages, first page must have the table as given in figure 1 and title block as given in figure 4, while the following pages of the specification with the title block given in figure 6.

Specification and drawing orientation must be identical. Specification table can be joined with the title block. If the specification is in the page with the drawing, records are inserted from bottom to top and the header row in the bottom. Field “**Identification number**” is replaced with the segment “**Material**”. Then:

- the field „**Position**“ includes the position mark, i.e. numbers of the assembled component same as in assembly drawing.
- „**Title**“ field includes the title of the part or unit.
- „**Number**“ field includes the total number of parts included to specification.
- **Additional information**“ may include any other information, e.g. mass of the part, hardness of the material etc.

POSITION	TITLE	IDENTIFICATION NUMBER	QUANTITY	REMARK
	<u>Documents</u>			
	Assembly drawing	BD INŽFXXXXX 08 03 SB	1	
	<u>Details</u>			
1	Moving ratchet	BD INŽFXXXXX 08 03 01	1	
2	Handle	BD INŽFXXXXX 08 03 02	2	
3	Marker	BD INŽFXXXXX 08 03 03	1	HRC 58...64
4	Spring	BD INŽFXXXXX 08 03 04	1	HRC 58...64
5	Stationary ratchet	BD INŽFXXXXX 08 03 05	1	
6	Axis	BD INŽFXXXXX 08 03 06	1	
7	Rubber bushing	BD INŽFXXXXX 08 03 07	1	HB 10...12
8	Spark plug head	BD INŽFXXXXX 08 03 08	1	A3, A4
	<u>Standard parts</u>			
9	Radial deep groove ball bearing DIN 625-6208		2	
10	Cylindrical pin LST ISO 2338-8m6x50-St		1	
11	Hexagon nut ISO 8674 - M16x1,5		1	
12	Hexagon socket head cap screw ISO 4762 - M6x12		4	
13	Parallel key A 14x9x80 DIN 6885		1	
Responsible dept XXXXXX		Technical reference Name Surname	Document type Assembly drawing	Document status Under approval
Legal owner VDU		Created by Name Surname	Title, supplementary title Holder	BD INŽFXXXXX 08 03 SB
		Approved by Name Surname		Rev. Date of issue Lang. Sheet 2021-12-14 EN 1

Fig. 5. First page of the specification table

POSITION	TITLE	IDENTIFICATION NUMBER	QUANTITY	REMARK
20	Spring	BD INŽFXXXXX 20 04 20	1	HRC 58...64
21	Bar spring	BD INŽFXXXXX 20 04 21	1	HRC 58...64
49	Bearing 306 GOST 8338 - 75		3	
50	Bearing 302 GOST 8338 - 75		1	
51	Parallel key A 16x10x80 DIN 6885		1	
<i>Legal owner</i> VDU		<i>Identification number</i> BD INŽFXXXXX 20 04 SB		<i>Sheet</i> 1

Fig. 6. Continuation of the specification table

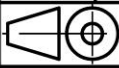
POSITION	TITLE	MATERIAL	QUANTITY	REMARK
13	Parallel key A 14x9x80 DIN 6885		1	
12	Hexagon socket head cap screw ISO 4762 - M6x12		4	
11	Hexagon nut ISO 8674 - M16x1,5		1	
10	Cylindrical pin LST ISO 2338-8m6x50-St		1	
9	Radial deep groove ball bearing DIN 625-6208		2	
8	Spark plug head	Steel C35 LST EN 10083-1:2006	1	A3, A4
7	Rubber bushing	ISO 48-2:2018	1	HB 10...12
6	Axis	Steel C35 LST EN 10083-1:2006	1	
5	Stationary ratchet	Steel C105U LST EN ISO 4957:2003	1	
4	Spring	Steel 50 Si7 LST EN 10089:2003	1	HRC 58...64
3	Marker	Steel 50 Si7 LST EN 10089:2003	1	HRC 58...64
2	Handle	Steel C45 LST EN 10083-1:2006	2	
1	Moving ratchet	Steel C35 LST EN 10083-1:2006	1	
				
Case templ_2021_1EN.dft		Additional information		Material
Scale 1:5				
Responsible dept. XXXXXX	Technical reference Name Surname	Document type Assembly drawing	Document status Under approval	
Owner VDU	Created by Name Surname	Title, supplementary title Holder	BD INŽFXXXXXX 20 04 SB	
	Approved by Name Surname		Rev.	Date of issue 2021-12-14
			Lang.	EN
			Sheet	4

Fig. 7. Specification table placed above assembly drawings title block